

# 1 Safety instructions

## Availability of documents

The Operating manual must be available at all times. The instructions must be read and understood before the device is used for the first time, and adhered to at all times.

## Service only by trained electricians

All work on the device (assembly, connection, commissioning, decommissioning, maintenance, repair, measurements and settings) may only be carried out by qualified electricians with relevant training on the prevention of accidents.

## Intended use

The device may only be used for the purpose intended by the manufacturer. Consult the chapter relating to intended use.

## Improper use

The device is subject to the manufacturer's warranty conditions valid at the time of purchase. The manufacturer will not accept any responsibility for unsuitable or incorrect manual or automatic parameter settings performed on a device or the inappropriate use of a device.

## Improper repairs

Repairs may only be performed by the manufacturer. Failure to comply will endanger the safety of the device and renders the warranty null and void.

## Permitted voltages

The voltage supply must meet the requirements for safety extra-low voltage ("Circuits and power sources of limited power" SELV).

## Regulations on electrical voltage

Users of devices which come into contact with electrical voltage must comply with the valid regulations. These are in particular, but with no claim to completeness, EN 60335, EN 60065, EN 50110, and the fire and accident-prevention regulations.

## Comply with national regulations

All work on the device and its installation must be carried out in accordance with the specifications of the national electrical regulations and local regulations.

## Essential safety equipment

The device may not be used as a safety component as defined by the Machinery Directive 2006/42/EG, the Construction Products Regulation 305/2011/EU or other safety regulations. Systems with a hazard potential require additional safety equipment!

## 2 Proper use

Induction loop detectors such as traffic detectors are operated in combination with various induction loops and electronic controller, such as frequency converters and PLC controller.

Areas of application are systems in the areas of traffic engineering, door and barrier controller, parking and tunnel monitoring as well as traffic light systems.

The traffic detectors of the LP21/LP22 series are intended for installation in a controller cabinet or a similar housing.

### **WARNING**

#### **Comply with the technical data**

The detector may only be operated with the prescribed supply voltages. Take note of the technical data before installation.

### **WARNING**

#### **Protection from environmental influences**

The device must be installed in a location where it will not sustain damage from heat, dripping water, moisture or dust.

#### **Incorrect use**

Alterations to the device and the use of spare parts and additional devices not sold or recommended by the manufacturer of the device may result in injuries and damage resulting from electric shocks and fires. Such actions result in a disclaimer of liability and forfeiture of the warranty.

#### **Impermissible interference with the housing**

Do not open the housing. This poses a danger to persons and the device functions and result in a disclaimer of liability and forfeiture of the warranty.

### 3 Product overview

#### 3.1 Housing dimensions

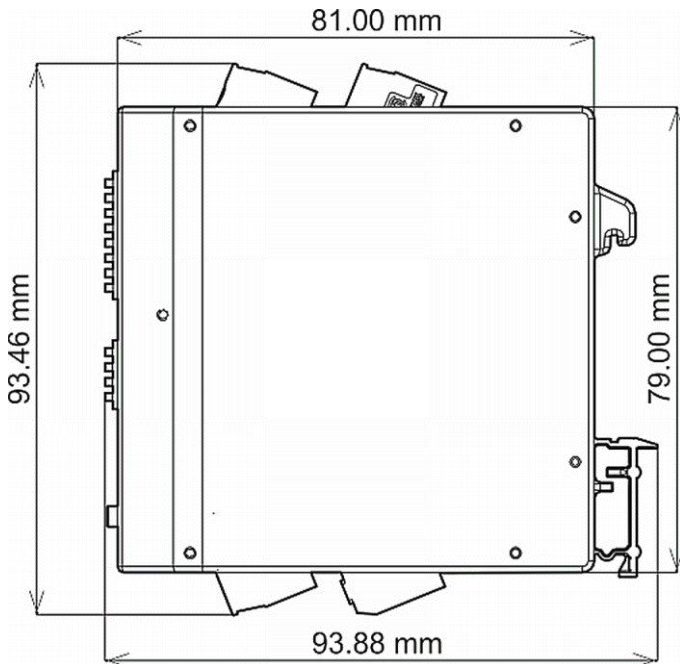

Fig.1: LP21/LP22 side view

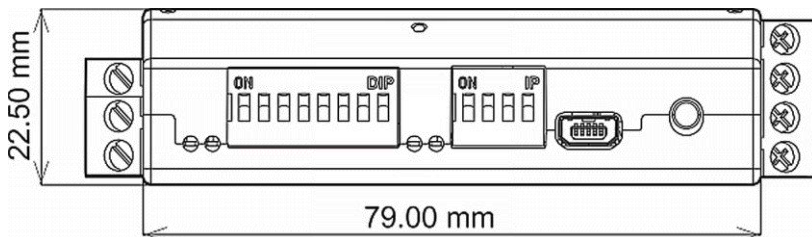

Fig.2: LP21/LP22 front view

### 3.2 Device components

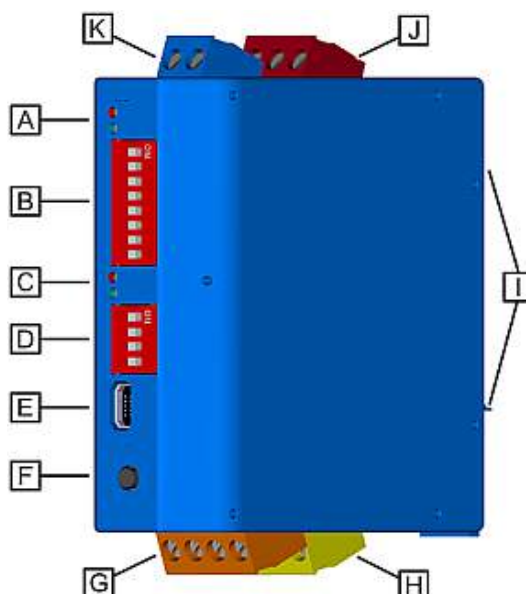

Fig.3: Traffic detector LP21/LP22

Index	Component	Description
A	Loop channel LEDs 1 (red + blue)	Status indicators for the loops and the detector
B	DIP switch 1	Basic settings for the detector
C	Loop channel LEDs 2 (red + blue)	Status indicators for the loops and the detector
D	DIP switch 2 (LP22 variant)	Basic settings for the detector
E	USB connection	Updates
F	Reset button	Factory settings or fresh adjustment
G	Loop inputs (orange)	Connections for induction loops
H	Output 1 terminal block: <ul style="list-style-type: none"> <li>• Relay output 1 (yellow)</li> </ul>	Signal outputs for controller
I	Mounting bracket	Mounting device for TS35 DIN rail
J	Output 2 terminal block: <ul style="list-style-type: none"> <li>• Relay output 2 (red)</li> </ul>	Signal outputs for controller
K	AC/DC connection (blue)	Connections for power supply

Tab. 1: LP21/LP22 Traffic Detector

### 3.3 Technical data

Specifications	
Housing	Plastic housing, ABS, blue
Mounting method	TS35 DIN rail
Dimensions	22.5 x 79.0 x 81.0 mm (W x H x L, without terminals)
Power supply (1 x blue)	2-pole terminal block (see Note 3) 10 – 30 VDC / 10 – 26 VAC (SELV) max. 2 W
Power consumption	Typically 500 mW
Protection class	III
Protection type	IP20
Environmental conditions	
• permitted operating temperature	-37 – +70 °C
• permissible storage temperature	-40 – +85 °C
• relative humidity	< 95 % (non-condensing)
Loop properties	
• max. inductivity range	20 - 700 $\mu$ H (see note 1)
• recommended inductivity range	100 – 300 $\mu$ H
• operating frequency	30 – 130 kHz
• cable length	200 m
• internal resistance	20 $\Omega$ (including cable)
• min. insulation resistance to earth	100 k $\Omega$ (constant, including cable)
• insulation voltage, loop inputs	1 kV (galvanic isolation)
Cycle and reaction time	12 ms (independent of loop channels)
Maximum speed for vehicles	
• presence detection	Max. 200 km/h
• direction detection (dual-channel variants)	Max. 200 km/h (at loop head distance of 2 m)

Specifications	
Inputs	
• 1 x loop (1 x orange, single-channel variants)	2-pole terminal block (see Note 3)
• 2 x loop (1 x orange, dual-channel variants)	4-pole terminal block (see Note 3)
Outputs	
• 2 x relays (1 x yellow, 1 x red)	3-pole terminal block (see Note 3) Max. 48 V (AC/DC), 2 A, 60 W, 125 VA (SELV) Min. 1 mA / 5 V (see note 2)
Configuration switch 1	8-pole DIP switch
Configuration switch 2 (dual-channel variants)	4-pole DIP switch
LED status indicator	1 x blue and 1 x red (per loop channel)
Reset button	Push button
PC interface	USB port, type mini AB

Tab.2: Specifications

**NOTE****1) Limitations on loop inductance**

For loop inductances outside the recommended range, only one frequency level may be available. For very small loop inductances, the maximum loop resistances are lower.

**2) Current load of the relay contacts**

The rigid gold plating on the relay contacts will be destroyed if the switching current exceeds 100 mA. Relays with contacts that are prestressed in this manner can only reliably switch currents over 100 mA!

**3) Terminal block data**

Grid dimension 5.0 mm, conductor cross-section 0.25 - 2.5 mm<sup>2</sup>, AWG 24-12

## 4 Product description

Induction loop detectors such as traffic detectors are electronic sensors for inductive detection of metallic objects. Using induction loops, for example, vehicles are detected, and depending on the device, their design and direction of movement.

The traffic detectors are operated in combination with various induction loops and electronic controller, such as frequency converters or PLC controller.

The areas of application are, for example, the detection, monitoring and counting of vehicles in the areas of traffic engineering, door and barrier controller, parking and tunnel monitoring as well as traffic light systems.

### 4.1 Product versions

The Traffic detector is available in the following versions:

Product name	Features
<b>LP21 (1 CHANNEL)</b>	<ul style="list-style-type: none"> <li>• 1 Channel for one induction loop</li> <li>• 2 Relay outputs</li> <li>• 8-pole DIP switch for configuration</li> <li>• USB diagnostic interface</li> <li>• Reset button</li> <li>• 24 V supply voltage</li> <li>• Top hat rail mounting</li> <li>• Plastic housing</li> </ul>
<b>LP22 (2 CHANNEL)</b>	<ul style="list-style-type: none"> <li>• 2 Channels for two induction loops</li> <li>• 2 Relay outputs</li> <li>• 8-pole DIP switch for configuration</li> <li>• 4-pole DIP switch for configuration</li> <li>• USB diagnostic interface</li> <li>• Reset button</li> <li>• 24 V supply voltage</li> <li>• Top hat rail mounting</li> <li>• Plastic housing</li> </ul>

Tab.3: Product versions

#### NOTE

##### Systems with high switching frequency

The use of detectors with digital outputs is recommended for systems with a high switching frequency. A restricted switching cycle limits the operational life of relay contacts.

## 4.2 Product characteristics

The traffic detectors have the following properties:

- 1 loop channel (LP21) or 2 loop channels (LP22)
- 2 potential-free relay outputs with changeover contact
- 8-pole DIP switch for configuration
- 4-pole DIP switch for advanced configuration (LP22)
- 2 or 4 LEDs for the indication of detector and loop states
- USB interface
- Connection for power supply (AC/DC)
- Galvanic isolation between loops and electronics
- Automatic adjustment of the device after switch-on
- Continuous adjustment of frequency drifts to suppress environmental influences
- Sensitivity independent of loop inductance
- Fixed hold times regardless of the loop coverage
- Direction detection based on two loop channels (LP22)
- Multiplexing prevents mutual interferences of the loop channels (LP22)
- Compact plastic housing for mounting on DIN rail in control cabinet

## 4.3 Product functions

The traffic detectors offer the following setting options:

- Switching between two frequency levels
- Output as presence or pulse signal or of direction (dual-channel variant LP22)
- Response threshold adjustable in 4 steps with DIP switch
- Hold time adjustable: 5 minutes or infinite with DIP switch

Advanced functions of the dual-channel variants:

- Selection of direction logic



### 4.3.1 Vehicle detection

Whether a metallic object is located in the loop area is identified via an LC oscillator (electrical oscillatory circuit). The channel output is switched according to the output function configured.

### 4.3.2 Output signals

Depending on the output configuration, presence, pulse or direction signals and direction logics (LP22) as well as loop faults are output.

For the pulse signal, it is also possible to select whether an output should occur when a loop is driven past or vacated.

In addition to inversion of the output signal, both outputs can individually be permanently switched on or off.

### 4.3.3 Alignment of the loop channels

When the detector is switched on or the reset button on the front is pressed for one second, an alignment of the loop channels is run.

If there has been an interruption of power, an automatic alignment only takes place if the operating voltage has been interrupted for at least 0.5 seconds. Alignment takes around one second if no vehicles drive over the loop in this time.

External influences on the loop frequency may result in longer alignment times, and their causes must be determined and eliminated.

### 4.3.4 Scanning of the loop channels

The dual-channel traffic detector LP22 can evaluate two loop channels.

The timed scanning of the loops is carried out in multiplex mode. They are connected to the common oscillatory circuit oscillator over a multiplexer. This prevents the loops interfering with each other.

The connected induction loops are switched on and off in rapid succession. Current is only ever supplied to one loop at a time. This means that both loops can be operated at the same frequency.

The cycle time of a scan in multiplex mode is 12 ms.

### 4.3.5 Loop error detection

*Loop closure* and *loop break* are identified as loop errors.

If no induction loop is connected to the loop channel, this corresponds to a *loop break* error status.

Once a loop error has been detected, the loop channel switches off. This may cause the available operating modes to be restricted, for example direction detection.

## 5 Description of connections

In the following section, the connections for the inputs and outputs are described.

### 5.1 Power supply

The detector can be operated with direct or alternating current, according to the requirements for Safety Extra-Low Voltages (SELV) of Protection Class III.

**WARNING**

**Note the permitted power supply**

Comply with the technical data and safety instructions!

The power supply is connected to the blue terminal block.



Fig.3: Power supply connection (blue)

### 5.2 Loop inputs

Up to two analogue inputs for the induction loops on the terminal block are located on the underside of the traffic detector. The terminal block is either 2-pole or 4-pole, depending on the product variant.

The induction loops are connected to the orange terminal blocks as shown in the illustration.

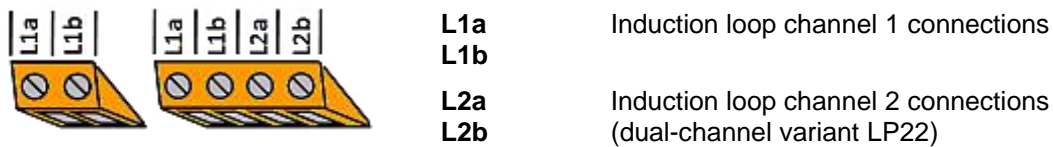

Fig.4: Loop connections (orange)

### 5.3 Signal outputs













The relay variants are intended particularly for situations which require mechanical switches with high power outputs.

#### 5.3.1 Relay outputs with changeover contact

The relays are designed as changeover contacts. Thus the outputs can be connected as normally closed (NC) or as normally open (NO). The relays are potential-free and suitable for many different types of switching modes.

All signal outputs can be inverted. In this case, when the power supply is turned on, normally open contacts function as normally closed contacts, and vice versa. This happens by switching between open-circuit and closed-circuit principle.

Loop malfunctions can also be interpreted as *loop covered* or as *loop free*.

Status	Normally closed contact (NC)		Normally open contact (NO)	
	Not inverted (open-circuit principle)	Inverted (closed-circuit principle)	Not inverted (open-circuit principle)	Inverted (closed-circuit principle)
Power supply off				
Detector ready, loop free				
Loop covered				

Tab.4: Switching states of the signal outputs

The analogue outputs of the relay variants are connected to the red and yellow terminal blocks according to the following illustration.

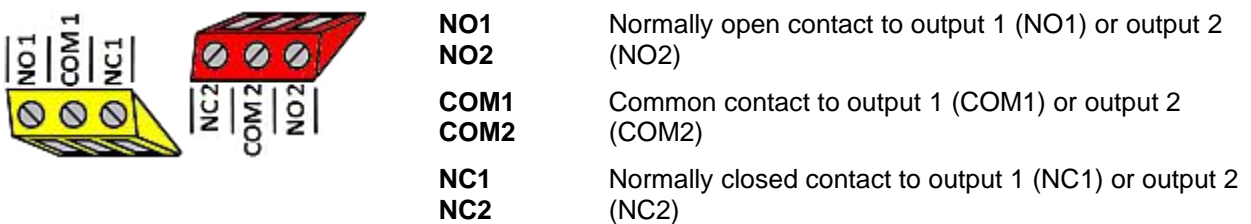

Fig.5: Relay connections 1 (yellow) and 2 (red)

## 6 Assembly and electrical installation

In the following section, assembly and electrical installation are described.

### NOTE

---

#### Illustrations and technical data on the device

You can find illustrations and technical data on the housing and connections in the sections at the beginning of this document.

---

### 6.1 Assembly on the DIN rail TS35

#### Prerequisites

---

#### Assembly conditions

Tools: none

Mounting device: DIN rail TS35 (top hat rail)

---

#### Fixing to the top hat rail

1. Place on the device from above with the groove on the top hat rail and lock the clip underneath.
2. Check that it is sitting securely.
  - The detector is ready for commissioning.

## 6.2 Connecting the power supply

### WARNING

#### Maintain the permitted voltages

The following voltage supplies are permitted:

- 10 - 30 VDC
- 10 - 26 VAC

Consult the chapter *Description of connections*.

### PREREQUISITES

#### Connect the inputs and outputs with no voltage present

All inputs and outputs must be connected before switching on the voltage supply.

### TOOLS

- Insulated flat-head screwdriver (width: 2 – 3 mm)

#### Connecting the power cable

1. Follow the warning and safety instructions and take the appropriate precautions.
2. If necessary, pull the terminal block out of the socket.
3. Loosen the screws on the blue terminal block.
4. Insert up to 5 mm of stripped supply cable into the slots at the side of the blue terminal block and fix.
5. Tighten the respective screw.
6. If necessary, insert the terminal block back into the blue 2-pole socket.  
→ The supply cable is firmly attached to the terminal block with no exposed wires.

#### Connect the power cable to the power source

1. Comply with the warnings and safety instructions for the external device.
2. Follow the manufacturer's instructions on wiring the outputs on the external device.  
→ The power cable is connected to the power source.

## 6.3 Connect the relay outputs

### TOOLS

---

Insulated slotted screwdriver (width 2 – 3 mm)

---

#### Connecting the relay outputs

1. Follow the warning and safety instructions and take the appropriate precautions.
2. If necessary, pull the red or yellow terminal block out of the socket.
3. Loosen the screws on the blue terminal block.
4. Insert up to 5 mm of stripped cable into the slot on the side of the terminal block and fasten.
5. Tighten the screw.
6. If necessary, insert the terminal block back into the red or yellow 3-pole socket.
  - The cables of the relay outputs are firmly attached to the terminal block with no exposed wires.

#### Connect the relay cable to the external device

1. Comply with the warning and safety instructions for the external device.
2. Follow the manufacturer's instructions on wiring the outputs on the external device.
  - The relay outputs are connected to the signal outputs on the external device.

## 6.4 Installing the induction loops

- The induction loops must be installed with a clearance of min. 15 cm to fixed metal objects and 1 m to mobile metal objects. The clearance to the surface of the final road surface should not amount to more than 5 cm.
- It is vital that the loop cable is installed separately from the supply lines
- A normal single pole cable with a cross section of 1.5 mm<sup>2</sup> must be used as a loop cable.
- If buried in the ground, the cable must be equipped with suitable insulation. If you use hot sealing compound, make sure the cable has a suitable temperature stability.
- Induction loops should preferably be realised in squares or at right angles. If it is not possible to use finished loops, they should be installed in a groove cut in the road surface as shown in the figure below. The loop cable must be fixed well in the groove. Then fill the groove with sealing compound. The corners should have a 45° angle to avoid damage to the cable insulation.

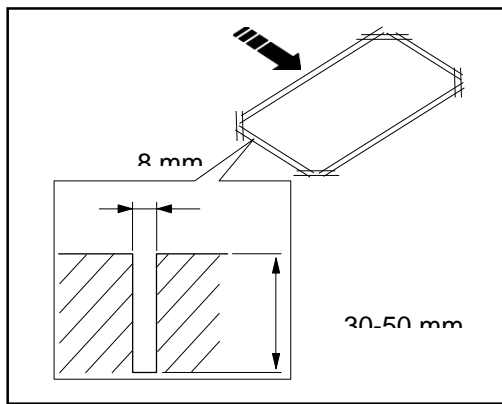

Fig.7: Installing the loops

- When installing the cable, comply with the number of turns specified in the table.

Scope of the induction loop	Number of turns
Smaller than 3 m	6
3 - 4 m	5
4 - 6 m	4
6 -12 m	3
Larger than 12 m	2

Tab.5: Number of turns on the loop cable

- The two cable ends leading from the induction loop to the detector (loop supply line) must be twisted with min. 20 strokes/m.
- Avoid dividing the cable. Should is be necessary to divide the cable, protect the clamp points against moisture penetration with cast resin collars.

## 6.5 Connecting the induction loops

### RECOMMENDATIONS

---

The requirements for the induction loops differ according to the area of application. Allow the supplier to advise you on installation of the induction loops.

---

### PREREQUISITES

---

The induction loops are already installed and ready for use.

---

### TOOLS

---

- Insulated slotted screwdriver (width: 2 – 3 mm)
  - Induction loops for the respective area of application
- 

### Connecting the induction loops

1. Follow the warning and safety instructions and take the appropriate precautions.
2. If necessary, pull the orange terminal block out of the socket.
3. Loosen the screws on the blue terminal block.
4. Insert up to 5 mm of stripped cable into the slot on the side of the terminal block and fasten.
5. Tighten the screw.
6. If necessary, insert the terminal block back into the orange 4-pole socket.
  - The induction loops are firmly attached with no exposed wires.



## 7 Commissioning

### Prerequisites

---

#### Assembly and electrical connection

- The system is not in use.
  - All work must be carried out by qualified specialist personnel.
  - All available cables are firmly attached to the terminal block.
  - The terminal blocks are sited on the input and output sockets of the same colour.
  - The detector is firmly mounted on the top hat rail.
- 

### Tools

---

#### Tools for the system

Always comply with the manufacturer's instructions!

No tools are required to commission the system.

---

### Commissioning the detector

1. Define the settings with the DIP switches.
2. Switch on the power supply to the detector.
  - The LP21/LP22 series detectors automatically run a test of the induction loops as well as a frequency alignment.
  - The detector is ready for operation when the blue LEDs are continuously lit. There is more information in the chapter on LED indicators.
3. Start up all components of the system (comply with the manufacturer's instructions).
4. Carry out a functional test of the system (comply with the manufacturer's instructions).
  - The detector is ready for continuous operation.

### NOTE

---

#### Optimising the detector settings

The device settings can be changed using the DIP switch while it is operating.

---

## 8 Description of functions

In the following section the indicator and control elements are described.

### NOTE















#### Information in this document

This document refers to the default settings or default values defined by the manufacturer. The factory settings of customer variants may differ from the manufacturer’s specifications. Please observe the instructions on the device, as well as the documents supplied with it.

### 8.1 LED status indicators

The LEDs (light emitting diodes) on the front side indicate the state of the loops and the detector. There are two LEDs for each loop channel:

- The red LED indicates the coverage status of the respective loop
- The blue LED indicates the operating status of the detector

Red LED	Blue LED	Description of status
		No power supply, detector inactive
		Detector ready, loop connected, no object detected
		Detector ready, loop connected, object detected
		No loop connected, loop break, loop closure
	 1 Hz	Ready for operation following earlier, now rectified, loop error
	 5 Hz	Frequency alignment is running
 	 	After frequency adjustment, both LEDs simultaneously display the set loop frequency in a flash code (see <i>Flash code</i> illustrated example)

Tab.6: LED signal colours

#### Key to LED symbols

-  Lit up
-  Off
-  Flashing
-  Frequency

#### LED flash code following a frequency alignment

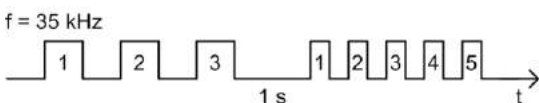

Fig.8: LED display of loop frequency

**NOTE**

## LED position

The LEDs for the loop channel 1 are located at the top or side of the device, for loop channel 2 are in the middle.

**8.2 DIP switch settings**

Function	Description
Sensitivity	Switch-on threshold for signal output when the loop is covered
Frequency level	Frequency of the loop resonant circuit in two levels
Hold Time until readjustment	Maximum duration of the output signal until automatic frequency adjustment of the loop channel
Output signal 2 mode	Switching between continuous signal and pulse signal at output 2
Time of output signal 2	Time of output signal for activated pulse signal on output 2
Output signal inversion	Reversing the switching logic for the output signals (inversion)
Direction detection	Switching between presence and direction detection for both outputs (2 channel variant LP22)
Direction logic	Evaluation logic of the direction of travel when loop is covered according to the specific application (read the operating instructions!)

*Tab.7: Description of the settings*

**8.2.1 DIP switch assignment of the LP21 variants**

The single-channel variants have an 8-pole DIP switch for configuring the detector.

DIP	Designation	Function
1	Sense a	Loop 1 sensitivity
2	Sense b	Loop 1 sensitivity
3	Frequency	Frequency step
4	Hold time	Hold time until readjustment
5	Output 2	Output signal 2 mode
6	Edge 2	Output signal 2 time
7	Inv. Out 1	Output signal 1 inversion
8	Inv. Out 2	Output signal 2 inversion

*Tab.8: DIP switch assignment (default)*

The following parameters can be adjusted with the DIP switch:

DIP switch	Position	Value
Sense a	ON	0.01% (high)
Sense b	ON	
Sense a	OFF	0,04%
Sense b	ON	
Sense a	ON	0,16%
Sense b	OFF	
Sense a	OFF	0.64% (low)
Sense b	OFF	
Frequency	OFF	low
	ON	high
Hold time	OFF	5 minutes
	ON	Infinite
Output 2	OFF	Pulse signal
	ON	Continuous signal
Edge 2	OFF	on entering
	ON	on leaving
Inv. Out 1	OFF	Output inverted
	ON	Output not inverted
Inv. Out 2	OFF	Output not inverted
	ON	Output inverted

Tab.9: Settings via DIP switch (LP21)

## 8.2.2 DIP switch assignment of the LP22 variants

The 2 channel versions have an 8-pole and 4-pole DIP switch for configuring the detector.

DIP1	Label	Function
1	Sense 1a	Loop 1 sensitivity
2	Sense 1b	Loop 1 sensitivity
3	Sense 2a	Loop 2 sensitivity
4	Sense 2b	Loop 2 sensitivity
5	Frequency	Frequency level
6	Hold time	Hold time until readjustment
7	Output 2	Output signal 2 mode
8	Edge 2	Time output signal 2

Tab.10: DIP switch 1 occupancy (standard)

DIP2	Label	Function
1	Dir. Mode	Direction detection
2	Dir. Logic	Direction logic
3	Inv. Out 1	Output signal 1 inversion
4	Inv. Out 2	Output signal 2 inversion

Tab.11: DIP switch 2 occupancy (standard)

The following parameters can be adjusted with the DIP switch:

DIP switch	Position	Value
Sense 1a / 2a	ON	0.01% (high)
Sense 1b / 2b	ON	
Sense 1a / 2a	OFF	0,04%
Sense 1b / 2b	ON	
Sense 1a / 2a	ON	0,16%
Sense 1b / 2b	OFF	
Sense 1a / 2a	OFF	0.64% (low)
Sense 1b / 2b	OFF	
Frequency	OFF	low
	ON	high
Hold time	OFF	5 minutes
	ON	Infinite
Output 2	OFF	Continuous signal
	ON	Pulse signal
Edge 2	OFF	on entering
	ON	on leaving
Inv. Out 1	OFF	Output inverted
	ON	Output not inverted
Inv. Out 2	OFF	Output not inverted
	ON	Output inverted
Dir. Mode	OFF	Presence
	ON	Direction
Dir. Logic	OFF	Continuous signal 2
	ON	Wrong-way driver 1

Tab. 12: Settings via DIP switch (LP22)

### 8.3 Reset button

The device is reset using the reset button on the front as follows:

Function	Description	Press button	LED
Reset / Readjustment	Runs a frequency readjustment and clears the LED fault messages	1 second	Red LED flashes
Factory settings	Resets the device to factory settings (DIP switch default settings)	5 seconds	Blue LED flashes

Tab.13: Reset functions

## 9 Description of settings

The functions described below can be performed with the *Detector Tool* service program as well as with the DIP switch. The DIP switch provides the key default settings. Commissioning is not possible without the service program.

**NOTE**

- In order to reset to factory settings, hold the reset button down for 5 seconds.

Key to tables	
<b>DIP</b>	Information in this column shows the settings options for the DIP switch.

**NOTE**

**Information in this document**

This document refers to the default settings or default values defined by the manufacturer. The factory settings of customer variants may differ from the manufacturer's specifications. Please observe the instructions on the device, as well as the documents supplied with it.

## 9.1 Adjusting sensitivity (switch-on threshold)

The switch-on threshold can be selected in 255 increments in the range between 0.01% and 2.55%  $\Delta f/f$ . The higher the switch-on threshold, the lower is the sensitivity for signal activation.

### Typical settings

- Generally speaking, sensitivity is adjusted in large steps, and the switch-on threshold selected is not greater than 640.
- Switch-on thresholds of over 640 and fine tuning may not be required for differentiation between vehicles. It is possible to differentiate, for example, buses with large loops (e.g. 10.0 m x 2.5 m) and correspondingly high threshold values (>1000).

### NOTE

#### Minimising interference factors

In order to minimise interference factors, the sensitivity should be as low as possible, i.e. the value of the switch-on threshold should be as high as possible.

DIP (Sense a)	DIP (Sense b)	Sensitivity ( $\Delta f/f$ )
ON	ON	0.01 % Level high (highest sensitivity)
OFF	ON	Level medium-high
ON	OFF	0.16% Level medium-low
OFF	OFF	0.64% level medium-low (factory setting)

Tab.14: Sensitivity settings



## 9.2 Setting loop frequency (frequency step)

The operating frequency setting serves to prevent couplings.

### Interference between loops

Couplings may occur between adjacent loops or loop connections from other detectors. Therefore, loops less than 2 metres apart should not operate at the same loop frequency. In this case a frequency spacing of at least 5 kHz must be maintained.

### Loop frequency indicator

The operating frequency of the loops after switching on or changes is reflected with an LED flash sequence.

### Multiplexing

No coupling between the loops of a detector takes place through multiplexing (2 channel version). The loops on a detector may therefore operate on the same frequency.

### NOTE

#### Loop inductivity range

In the event of loop inductivity outside the recommended range, the available frequency range may be restricted.

DIP (frequency)	Frequency step
OFF	low (factory setting)
ON	High

Tab.15: Loop frequency settings

### 9.3 Setting hold time

Separate hold times between 1 and 255 minutes can be set at the detector for each channel. The value 0 corresponds to an infinite hold time. If the loop on a detector channel is covered for longer than the set hold time, the detector channel runs a frequency alignment. The current detuning of the loop channel is reset.

#### Limiting the hold time

Limiting the hold time can be used, for example, to remove the vehicle parking on the loop automatically once the hold time has ended. The loop can then be reused for subsequent vehicles. Permanent activation caused by faults can also be avoided by setting the hold time appropriately.

DIP (hold time)	Hold time
ON	infinite
OFF	5 min

Tab. 16: Hold time settings (LP21/LP22)

### 9.4 Setting output mode (signal type)

Various output modes (signal types) can be set for the outputs.

#### WARNING

#### Switching off the direction logic (2 channel version)

The direction logic must be switched off to set the output mode, i.e. *Dir. Mode* on the DIP switch must be set to OFF.

DIP (output 2)	Output signal
OFF	constant signal (factory setting)
ON	Impulse signal

Tab. 17: Signal type settings

## 9.5 Inverting the signal output (signal behaviour)

An inverted or a non-inverted signal can be selected for all outputs. Consult the chapters pertaining to the signal outputs (see chapter 5.3 "Signal outputs", page 11) and the DIP switch settings (see chapter 8.2 "DIP switch settings", page 19).

### NOTE

#### Controlling signal behaviour

- The factory settings are specified in the short instructions and on the housing.

DIP (inv. out 1)	DIP (inv. out 2)	Signal behaviour
ON	ON	Signal output is not inverted
OFF	OFF	Signal output is inverted

Tab.18: Inversion of output signal

## 9.6 Setting output switching time (impulse time)

The switching time for the outputs can be defined in impulse signal mode.

### NOTE

#### Set impulse duration

The default impulse duration is 200 ms.

DIP (edge 2)	Impulse time
OFF	when the loop is driven past (factory setting)
ON	when the loop is freed up

Tab.19: Output impulse time

## 9.7 Setting direction detection (dual-channel variants)

Complex evaluation algorithms are integrated into the dual-channel detector for direction-dependent recording of vehicles over double loops. The direction logic generates logical output signals that are given out over the outputs depending on the setting. Parallel to this, the detector autonomously counts the logic signals.

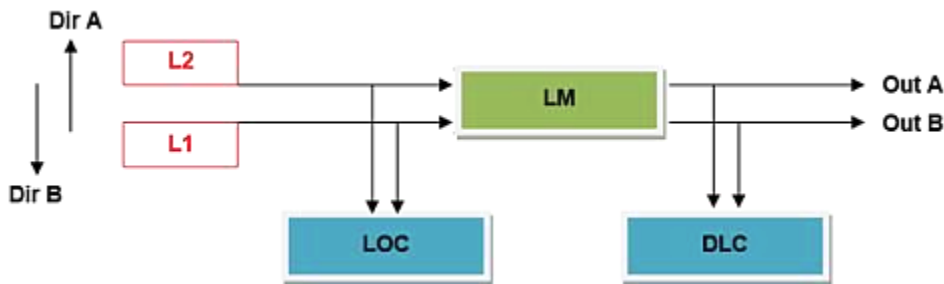

Fig.9: Direction detection principle

Symbol	Description
Dir A, Dir B	Direction A: Loop 1→Loop 2 or direction B: Loop 2→1
L1, L2	Loop 1 or 2
Out A, Out B	Signal output direction A or B
LM	Logic module
LOC	Loop coverage counter
DLC	Direction logic counter

Tab.20: Key to symbols

### Direction logic system

- With all the logics, the first loop covered determines the direction of counting or of travel. If loop 1 is covered first, the signal output and counting is done for direction A (see chapter 9.8 "Setting direction logic (dual-channel variants)", page 29).

### NOTE

#### Counter readings in the Detector Tool

- It should be noted that the counter overflows at 65,535 ( $2^{16}$ ) and is automatically erased.
- The counter readings are not protected against power failure!

DIP	Direction detection
OFF	Switched off (factory settings)
ON	Switched on

Tab.21: Setting direction detection

## 9.8 Setting direction logic (dual-channel variants)

A variety of evaluation logics can be set in the logic module, depending on the application.

**NOTE**

**Switching direction detection on**

It is only possible to set the direction logic when direction detection is activated!







DIP (Dir. Logic)	Direction Logic
OFF	Constant signal 2 (factory setting)
ON	wrong-way driver 1

Tab.22: Setting direction logic

The different logics for direction detection are described below.

abbr.	Direction Logic	Signal output	Signal drop	Note
D1	Continuous signal 1	Covering Loop 1	Leaving Loop 1	Output signal in opposite direction only occurs again if both loops were previously free.
DB	Continuous signal both		Leaving Loop 2	
D2	Continuous signal 2	Covering Loop 2		
F1	Wrong-way driver 1	Covering Loop 2	Pulse output with minimum signal duration (default: 200 ms)	Correct behaviour in the case of queues and manoeuvring. Different behaviour in wrong-way driver situation.
F2	Wrong-way driver 2			
BS	both loops			
FE	Feig	Leaving Loop 1		Correct behaviour in the case of queues and manoeuvring.
SF	Loop free	Leaving Loop 2		Recording single vehicles and manoeuvring. Queues should not occur.
PB	Parking bay	Direction-dependent		For short entrances and exits
Ri1	Direction 1			
Ri2	Direction 2			

Tab.23: Overview of direction logic

Symbol	Description
	Highlighted direction logic delivers false counts for this setting
	Pulse signal travel direction A
	Pulse signal travel direction B
	Continuous signal
	Loop free
	Loop covered

Tab.24: Key to direction logic

You can find information on the detailed functions for different traffic situations in the following section.

### 9.8.1 “Single vehicle” direction logic











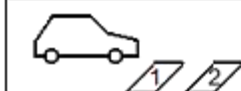







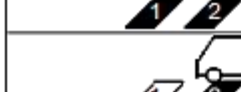

	D2	D1	DB	F1	F2	FE	SF	BS	PB Ri1 Ri2	
										
										
										
										
										

Fig.10: Single vehicle direction logic

9.8.2 “Queue” direction logic

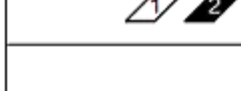
	D2	D1	DB	F1	F2	FE	SF	BS	PB	
									Ri1	Ri2
				A	A			A		
						A				A
									B	
				A	A			A		
						A				A
							A		A	

Fig.11: Queue direction logic

9.8.3 “Wrong-way driver” 1 direction logic

	D2	D1	DB	F1	F2	FE	SF	BS	PB	
									Ri1	Ri2
				A	A			A		
				B	B					

Fig.12: Wrong-way driver 1 direction logic

9.8.4 “Wrong way driver 2” direction logic





	D2	D1	DB	F1	F2	FE	SF	BS	PB	
									Ri1	Ri2
										
				A	A			A		
						A				A
										
									B	
					B					

Fig.13: Wrong-way driver 2 direction logic

9.8.5 “Manoeuvring” 1 direction logic



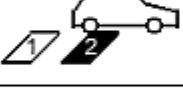

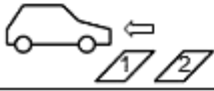
	D2	D1	DB	F1	F2	FE	SF	BS	PB	
									Ri1	Ri2
										
				A	A			A		
										
										
						A				A
							A		A	

Fig.14: Manoeuvring 1 direction logic



9.8.6 “Manoeuvring” 2 direction logic

	D2	D1	DB	F1	F2	FE	SF	BS	PB	
									RI1	RI2
				A	A			A		
						A				A
									B	
				A	A			A		
						A				A
							A		A	

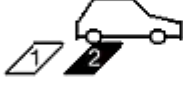
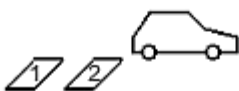
Fig.15: Manoeuvring 2 direction logic

9.8.7 “Wrong-way driver in queue” direction logic

	D2	D1	DB	F1	F2	FE	SF	BS	PB Ri1 Ri2	
				A	A			A		
						A				A
									B	
					B					

Fig. 16: “Wrong-way driver in queue” direction logic

### 9.8.8 Direction Logic “Cross traffic“



	D2	D1	DB	F1	F2	FE	SF	BS	PB	
									Ri1	Ri2
		↑	↑							
	↑	↑	↑	A	A			A		
	↑	↓	↑			A				A
	↑	↑	↑							
	↑	↓	↑						B	
		↓	↑		B					

Fig.17: Cross traffic direction logic

**NOTE**

**False counts**

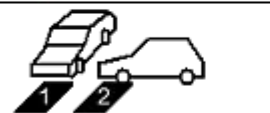
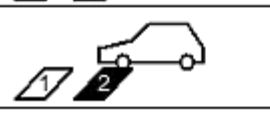
All logics except logic PB in direction 1 deliver false counts in this traffic situation, because they count entries instead of exits!

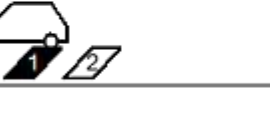
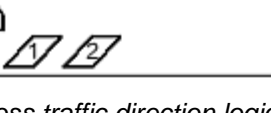
### 9.8.9 Direction Logic “Parking bay”

This direction logic is used where for short entrances and exits. Interference to counting due to cross traffic on loop 1 is disabled in this logic. This logic suppresses the impairment of counting by cross traffic on loop 1. It is therefore irrelevant whether loop 1 is laid in the adjoining lane or the manoeuvring area.

**WARNING**

**Positioning of the loops**

The positioning of *the* loops is dependent on the direction in which congestion is anticipated. No tailbacks are permitted to occur in travel direction 1 → 2. In travel direction 2 → 1, vehicles will also be correctly counted in congestion, and in this situation the gap between vehicles must release one loop at a time.

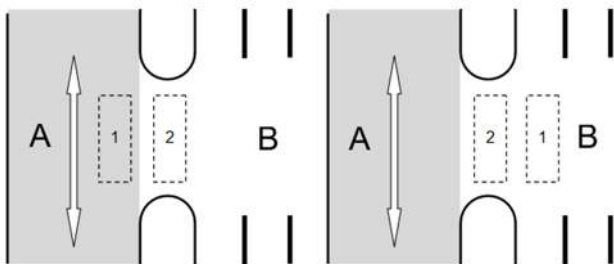

Fig.18: Parking bay Direction Logic

Symbol	Description
A	passageway
B	Car park
1	Loop 1
2	Loop 2

Tab.25: Symbols for parking bay

**Logic for travel direction 1 → 2**

- The counting pulse is triggered as soon as both loops have been completely crossed
- Correct counting with single vehicles
- Correct counting also with manoeuvring
- Congestion and queues are not permitted to occur in travel direction 1 -> 2!

**Logic for travel direction 2 → 1**

- The counting pulse is triggered as soon as loop 2 is vacated in the direction of loop 1.
- Correct counting also with cross traffic
- Correct counting with queues
- Correct counting also when a single vehicle is manoeuvring
- No manoeuvring is permitted to take place in a queue!

## 10 Maintenance & servicing

### Maintenance and repairs

This product does not require any maintenance or servicing.

In the event of malfunctions and faults, please contact the vendor or the manufacturer.

## 11 Decommissioning

### Conditions

---

#### System not functioning

The system is not in use.

All work must be carried out by qualified specialists.

---

### Tools

---

#### Tools for the system

Always comply with the manufacturer's instructions!

Insulated slotted screwdriver (width 2 – 3 mm)

---

### Decommissioning the detector

1. Switch off all components of the system (observe the manufacturer's instructions).
2. Switch off the power supply to the detector.
3. Check that there is no voltage to any of the supply cables.
  - The detector can be detached.
4. Carefully press down the mounting bracket with the screwdriver and pull the detector off the DIN rail.
5. Pull the terminal blocks out of the input and output sockets.
  - The detector can be detached. Remove all connectors as follows:
6. Loosen the screws holding the terminal blocks with a slotted screwdriver.
7. Pull the cable out of the mounting slots.
  - The detector is disassembled.

## 12 Disposing of the product



At the end of its service life, dispose of the product in accordance with the valid legal specifications.